

# SMT & THM POLARIZED LITHIUM-ION & ALKALINE CELL HOLDERS

# SMT & THM COIL SPRING BATTERY HOLDERS



### FEATURES

- UL 94V-0 Heat resistant nylon housing well suited for reflow and wave soldering operations
- Coil Spring will rebound after severe shock load
- Polarized holder offers circuit protection against improper battery installation
- Ideal for both lead free and traditional solder processes
- Operating temp range: -60°F to 293°F (-51°C to 145°C)

### APPLICATIONS:

- Computer memory, power backup systems
- Telecommunications
- Residential, Industrial and commercial security systems
- PLC and industrial controls

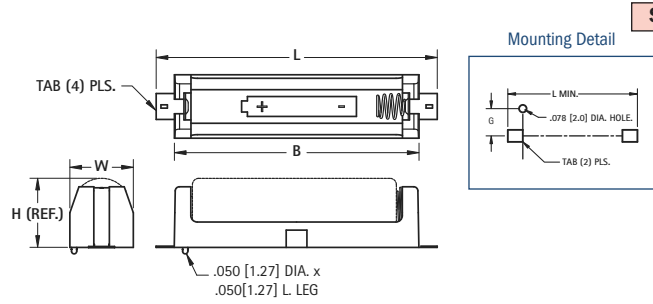

### SPECIFICATIONS

**Base:** High Temp Nylon 46 - UL94V-0  
**Contacts:** .012 (.30) Stainless Steel .020 (0.50) Dia. Music Wire - Gold Plate (Flash)  
**Operating Temp Range:** -60°F to 293°F (-51°C to 145°C)  
**Packaging Spec's:** Supplied in trays

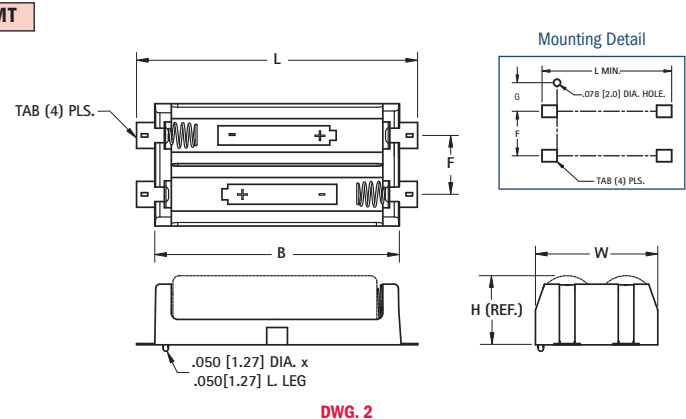

HOLDER	COVER								CELL SIZE	PACKAGING SPECS	BATTERY CROSS REFERENCE
CAT. NO.	COVER	DWG NO.	L	W	H (Ref. Dim)	B	F	G			
1076	1020C	1	2.421 (61.5)	.500 (12.7)	.445 (11.3)	2.140 (54.4)	-	.209 (5.3)	"AAA"	50 pieces per tray	All Major Manufacturers
1078	1022C	2	2.421 (61.5)	.875 (22.2)	.445 (11.3)	2.140 (54.4)	.430 (10.9)	.182 (4.6)	"AAA"	25 pieces per tray	
1088	1024C	1	2.711 (68.9)	.612 (15.5)	.603 (15.3)	2.359 (59.9)	-	.265 (6.7)	"AA"	50 pieces per tray	All Major Manufacturers
1090	1012C	2	2.711 (68.9)	1.180 (30.0)	.603 (15.3)	2.359 (59.9)	.568 (14.4)	.265 (6.7)	"AA"	25 pieces per tray	
1126	1024C	1	1.723 (43.8)	.612 (15.5)	.603 (15.3)	1.360 (34.5)	-	.265 (6.7)	"1/2 AA"	50 pieces per tray	Energizer 544, Duracell PX28L, Kodak K28A & KS28, Saft LCP3, Maxell 4LR44, Sanyo CR14250SE
1128	1018C	1	2.062 (52.3)	.720 (18.3)	.682 (17.3)	1.690 (42.9)	-	.319 (8.1)	"CR123A"	50 pieces per tray	Duracell DL2/3A, Kodak K123LA, Panasonic CR123A, Saft 450SC & VR0450,
1014	-	2	2.062 (52.3)	1.440 (36.6)	.682 (17.3)	1.690 (42.9)	.720 (18.3)	.319 (8.1)	"CR123A"	25 pieces per tray	Sanyo CR17335SE

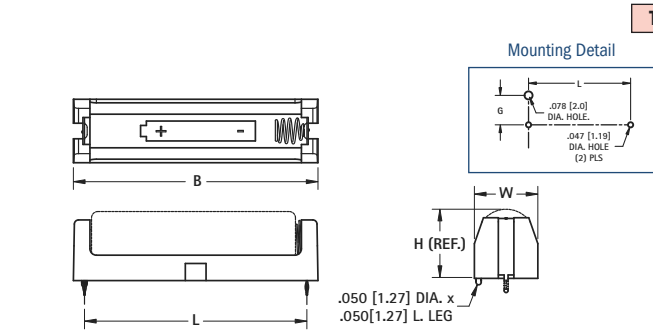

### SPECIFICATIONS

**Base:** High Temp Nylon 46 - UL94V-0  
**Contacts:** .012 (.30) Stainless Steel .020 (0.50) Dia. Music Wire - Nickel Plate  
**Packaging Spec's:** Supplied in trays

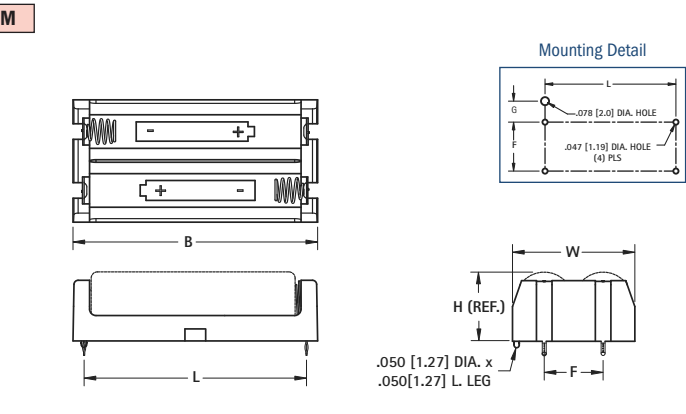

HOLDER	COVER								CELL SIZE	PACKAGING SPECS	BATTERY CROSS REFERENCE
CAT. NO.	COVER	DWG NO.	L	W	H (Ref. Dim)	B	F	G			
1075	1020C	3	1.933 (49.1)	.500 (12.7)	.445 (11.3)	2.140 (54.4)	-	.209 (5.3)	"AAA"	50 pieces per tray	All Major Manufacturers
1077	1022C	4	1.933 (49.1)	.875 (22.2)	.445 (11.3)	2.140 (54.4)	.430 (10.9)	.182 (4.6)	"AAA"	25 pieces per tray	
1087	1024C	3	2.145 (54.5)	.612 (15.5)	.603 (15.3)	2.359 (59.9)	-	.265 (6.7)	"AA"	50 pieces per tray	All Major Manufacturers
1089*	1012C	4	2.145 (54.5)	1.180 (30.0)	.603 (15.3)	2.359 (59.9)	.568 (14.4)	.265 (6.7)	"AA"	25 pieces per tray	
1127	1024C	3	1.156 (29.4)	.612 (15.5)	.603 (15.3)	1.360 (34.5)	-	.265 (6.7)	"1/2 AA"	50 pieces per tray	Energizer 544, Duracell PX28L, Kodak K28A & KS28, Saft LCP3, Maxell 4LR44, Sanyo CR14250SE
1129*	1018C	3	1.487 (37.8)	.720 (18.3)	.682 (17.3)	1.690 (42.9)	-	.319 (8.1)	CR123A	50 pieces per tray	Duracell DL123A, Kodak K123LA, Panasonic CR123A,
1055*	-	4	1.487 (37.8)	1.440 (36.6)	.682 (17.3)	1.690 (42.9)	.720 (18.3)	.319 (8.1)	CR123A	25 pieces per tray	Varta CR1213A, Sanyo CR123A

\*Base Material: PBT UL 94V-0