

# SURFACE MOUNT (SMT) & THRU HOLE (THM) BUTTON CELL RETAINERS

Economical and reliable SMT and THM coin cell retainers specifically designed for miniature electronic applications with limited board space.

- Available in Thru Hole Mount (THM) or Surface Mount (SMT) configurations
- Retains battery securely to withstand shock and vibration
- THM legs maintain relative position during and after soldering
- Ideally suited for High Density packaging
- Reliable spring tension assures low contact resistance
- SMT solder tail with "flow-hole" design for increased joint strength
- Solder tail located outside of retainer body which facilitates visual inspection of the solder joints

4.8mm to 10mm BUTTON CELL RETAINERS

**AVAILABLE ON TAPE AND REEL**

**4.8mm**



Surface Mount

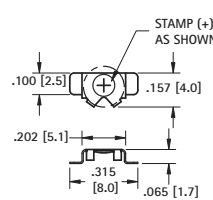

STAMP (+) AS SHOWN

MATERIAL: .006 (.15) Phosphor Bronze, Gold Plate (Flash)

CAT. NO. BULK	ON TAPE & REEL	BATTERY REFERENCE
2994	2994TR	ML414

Tape & Reel Spec's: 16mm wide; 8mm pitch; 13 inch reel (1500 pieces per reel)

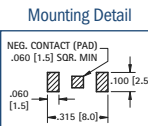

Mounting Detail



Thru Hole Mount

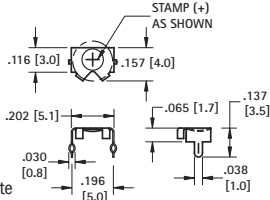

STAMP (+) AS SHOWN

MATERIAL: .006 (.15) Phosphor Bronze, Tin-Nickel Plate

CAT. NO.	BATTERY REFERENCE
2995	ML414

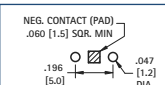

Mounting Detail

**AVAILABLE ON TAPE AND REEL**

**5.8mm**



Surface Mount

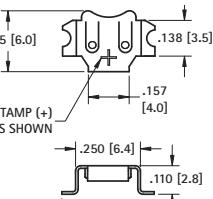

STAMP (+) AS SHOWN

MATERIAL: .006 (.15) Phosphor Bronze, Tin-Nickel Plate

CAT. NO. BULK	ON TAPE & REEL	BATTERY REFERENCE
2986	2986TR	379, 317

Tape & Reel Spec's: 16mm wide; 8mm pitch; 13 inch reel (1500 pieces per reel)

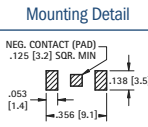

Mounting Detail



Thru Hole Mount

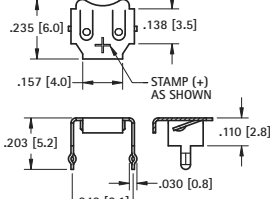

STAMP (+) AS SHOWN

MATERIAL: .006 (.15) Phosphor Bronze, Tin-Nickel Plate

CAT. NO.	BATTERY REFERENCE
2987	379, 317

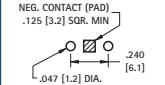

Mounting Detail

**AVAILABLE ON TAPE AND REEL**

**6.8mm**



Surface Mount

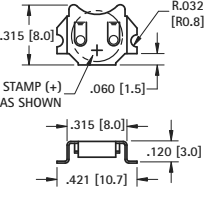

R.032 [R0.8]

STAMP (+) AS SHOWN

MATERIAL: .010 (.25) Phosphor Bronze

CAT. NO. BULK	ON TAPE & REEL	FINISH	BATTERY REFERENCE
2998	2998TR	Tin-Nickel	MC621, V364, SC621, DR13H, DR77, V13AT, 377
3098	3098TR	Matte Tin	

Tape & Reel Spec's: 24mm wide; 12mm pitch; 13 inch reel (1000 pieces per reel)

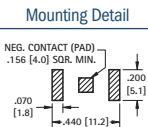

Mounting Detail



Thru Hole Mount

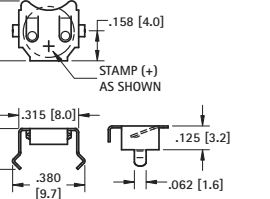

STAMP (+) AS SHOWN

MATERIAL: .010 (.25) Phosphor Bronze, Tin-Nickel Plate

CAT. NO.	BATTERY REFERENCE
2999	MC621, V364, SC621, DR13H, DR77, V13AT, 377

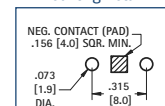

Mounting Detail

**AVAILABLE ON TAPE AND REEL**

**7.9mm**



Surface Mount

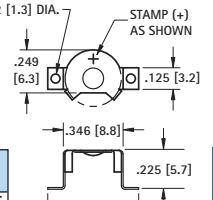

STAMP (+) AS SHOWN

MATERIAL: .010 (.25) Phosphor Bronze, Gold Plate (Flash)

CAT. NO. BULK	ON TAPE & REEL	BATTERY REFERENCE
2988	2988TR	Size 13, DA13, AZ13E, 393, SR754, SR48

Tape & Reel Spec's: 24mm wide; 12mm pitch; 13 inch reel (800 pieces per reel)

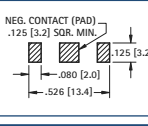

Mounting Detail



Thru Hole Mount

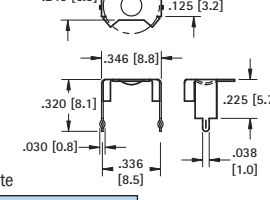

STAMP (+) AS SHOWN

MATERIAL: .010 (.25) Phosphor Bronze, Tin-Nickel Plate

CAT. NO.	BATTERY REFERENCE
2989	Size 13, DA13, AZ13E, 393, SR754, SR48

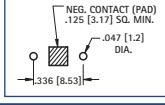

Mounting Detail

**AVAILABLE ON TAPE AND REEL**

**9 - 10mm**



Surface Mount

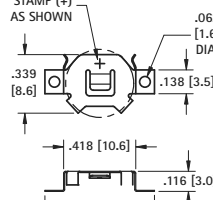

STAMP (+) AS SHOWN

MATERIAL: .006 (.15) Phosphor Bronze, Tin-Nickel Plate

CAT. NO. BULK	ON TAPE & REEL	FINISH	BATTERY REFERENCE
3030	3030TR	Tin-Nickel	CR927, CR1025
3050	3050TR	Matte Tin	

Tape & Reel Spec's: 24mm wide; 12mm pitch; 13 inch reel (1500 pieces per reel)

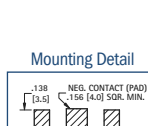

Mounting Detail



Thru Hole Mount

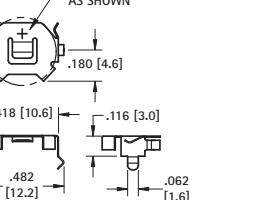

STAMP (+) AS SHOWN

MATERIAL: .006 (.15) Phosphor Bronze, Tin-Nickel Plate

CAT. NO.	BATTERY REFERENCE
3031	CR927, CR1025

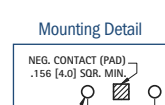

Mounting Detail