

THIS DOCUMENT IS THE PROPERTY OF KEYSTONE ELECTRONICS CORP. AND SHALL NOT BE REPRODUCED, DISTRIBUTED OR USED AS A BASIS FOR MANUFACTURE WITHOUT PRIOR WRITTEN PERMISSION FROM KEYSTONE ELECTRONICS CORP.

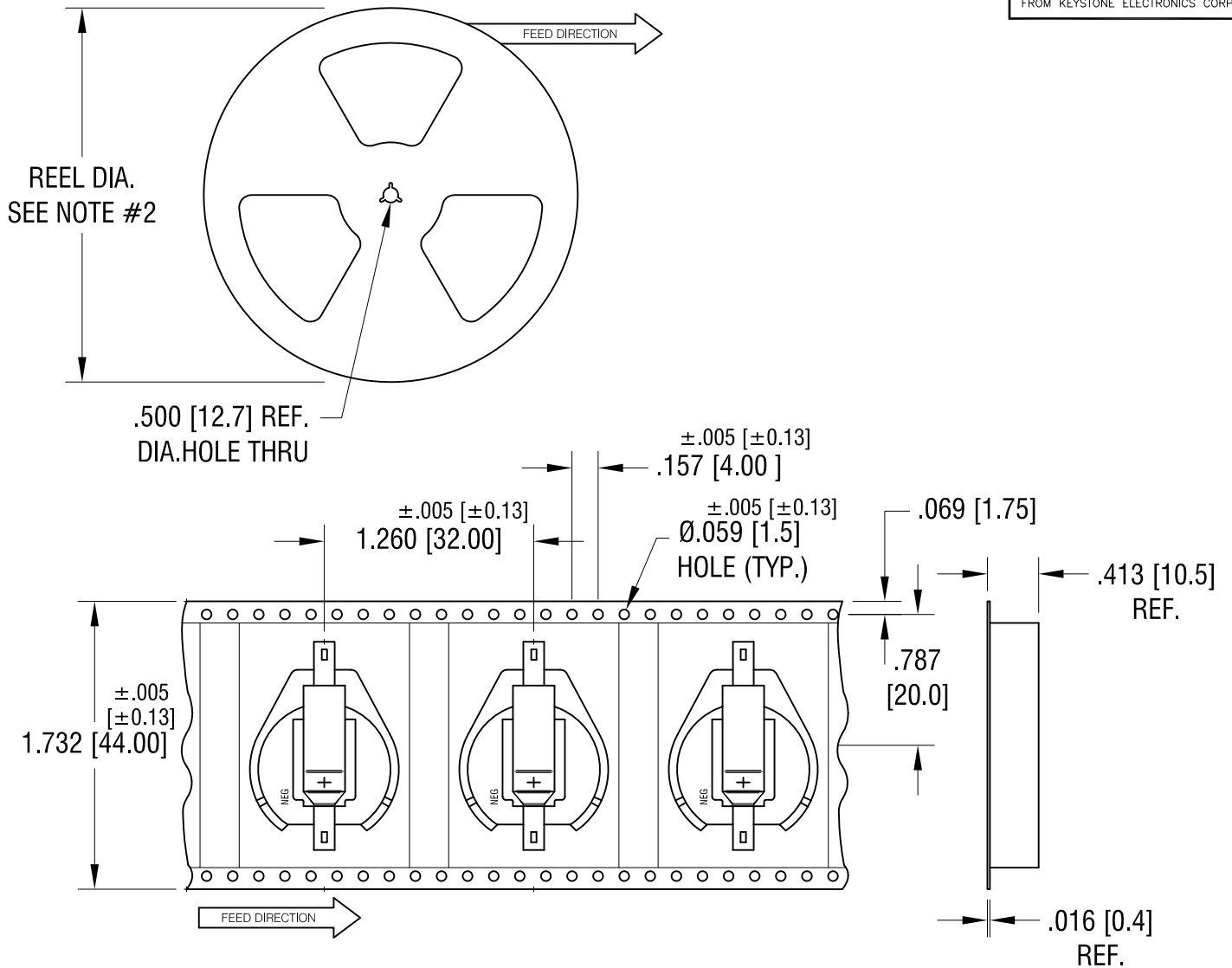

NOTES:

TAPE AND REEL SPECIFICATIONS:

1. TAPE:

MAT'L - ALL CONDUCTIVE POLYSTYRENE CARRIER
ANSI/EIA-481 STANDARD
1.732 [44.0] WIDE; 1.260 [32.0] PITCH

2. REEL:

13.0 [330.2] DIA. 200 PIECES OF
PART NO. 1063 PER REEL.

3. MSL PACKAGING (1) ONE REEL PER BAG

KEYSTONE ELECTRONICS CORP.

www.keyelco.com • NEW HYDE PARK NY 11040 • Tel (516)328-7500

PART NAME

20mm SM COIN CELL HOLDER ON TAPE&REEL

MATERIAL

AS NOTED

FINISH

AS NOTED

DRN BY

BOONE

DATE

5.08.00

APP'D

RH

SCALE

X

TOLERANCES

INCH [MM]

DECIMAL

±.015 [±0.38]

ANGULAR

± 1°

UNLESS OTHERWISE SPECIFIED

CODE

C

DWG NO.

1063TR

9.15.23

CHANGE AS PER ECN 23-160

B

6.19.07

CHANGE AS PER ECN 07-037

A

DATE

DESCRIPTION

REV.

MOUNTING DETAIL

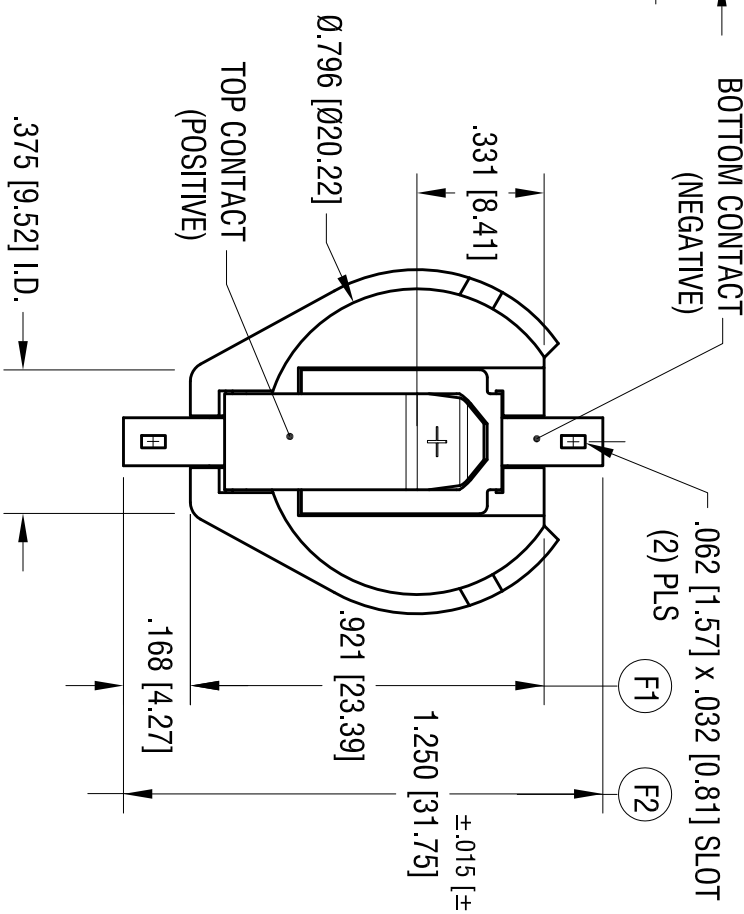
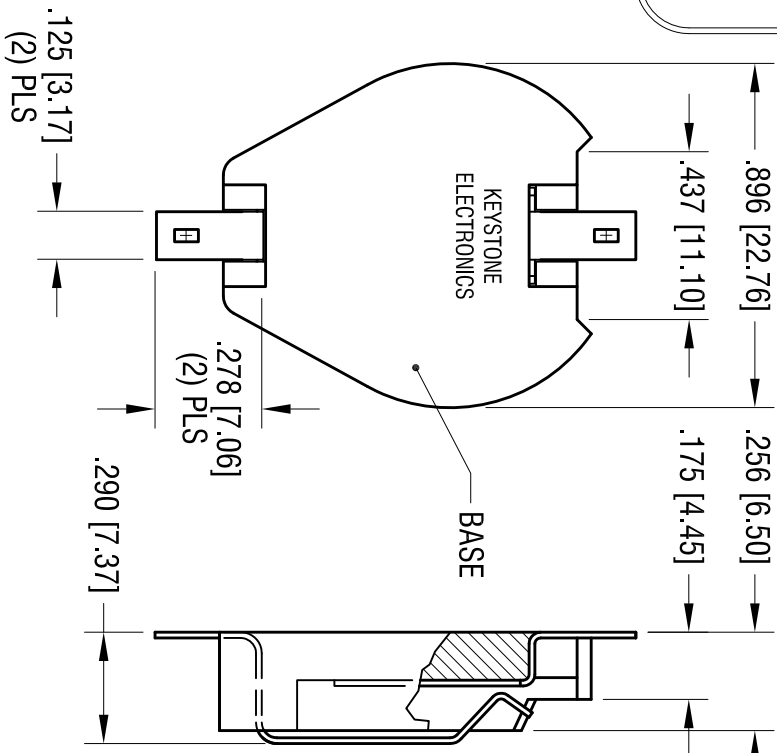
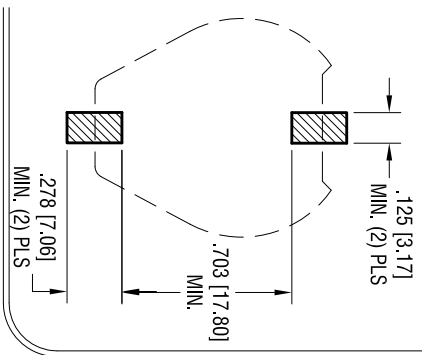

DATE	DESCRIPTION	REV.
9.17.04	CHANGE AS PER ECN 04-106	C
7.05.11	ECN 11-090 SPLIT C/M TO 'C' & 'M'	D
8.15.11	CHANGE AS PER ECN 11-108	E
1.10.22	ECN 22-008, (F1) WAS.931 (F2) WAS 1.250±.010	F
9.18.23	PER ECN23-163 ADDED PACKAGING	G

NOTES:

1. BASE:
MATEL - HIGH TEMPERATURE NYLON (UL 94V-0)
COLOR BLACK
2. CONTACTS (TOP AND BOTTOM):
MATEL - .015 [0.38] THK SPRING STEEL
FINISH: TIN NICKEL PLATE
3. BATTERY HOLDER SUPPLIED IN MSL-2 PACKAGING

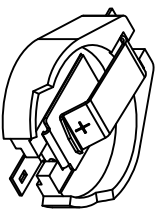

ACTUAL SIZE

THIS DOCUMENT IS THE PROPERTY OF KEYSTONE ELECTRONICS CORP. AND SHALL NOT BE REPRODUCED, DISTRIBUTED OR USED AS A BASIS FOR MANUFACTURE WITHOUT PRIOR WRITTEN PERMISSION FROM KEYSTONE ELECTRONICS CORP.

KEYSTONE ELECTRONICS CORP.			
www.keystoneco.com • NEW HYDE PARK, NY 11040 • Tel (516) 328-7500			
PART NAME 20mm BATTERY HOLDER, SMT			
MATERIAL AS NOTED			
FINISH AS NOTED			
TOLERANCES	INCH	[MM]	CODE
DECIMAL	± .010	[± 0.25]	C
ANGULAR	± 1°		
UNLESS OTHERWISE SPECIFIED			
DRN BY	BOONE	DATE	8.9.95
APP'D	RH	SCALE	2X
DWG NO.		1063	