

THIS DOCUMENT IS THE PROPERTY OF KEYSTONE ELECTRONICS CORP. AND SHALL NOT BE REPRODUCED, DISTRIBUTED OR USED AS A BASIS FOR MANUFACTURE WITHOUT PRIOR WRITTEN PERMISSION FROM KEYSTONE ELECTRONICS CORP.

ACTUAL SIZE

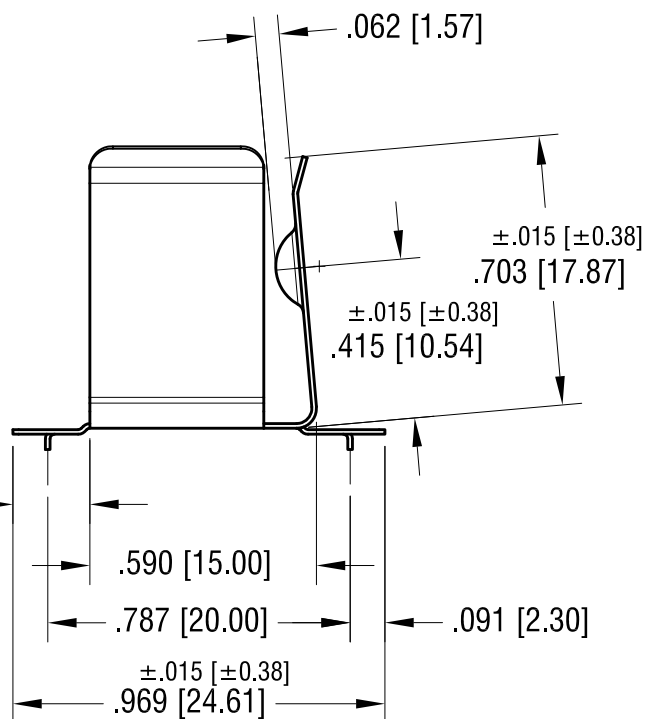
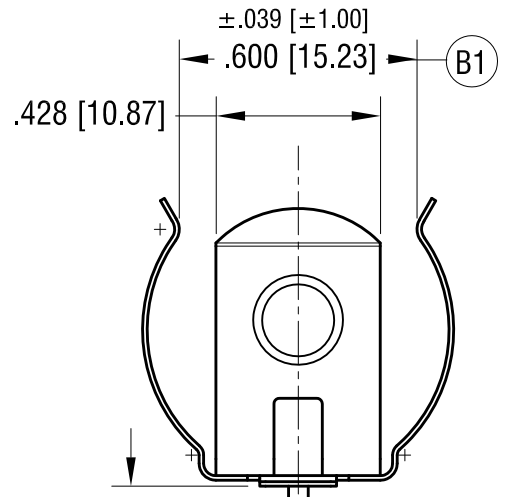
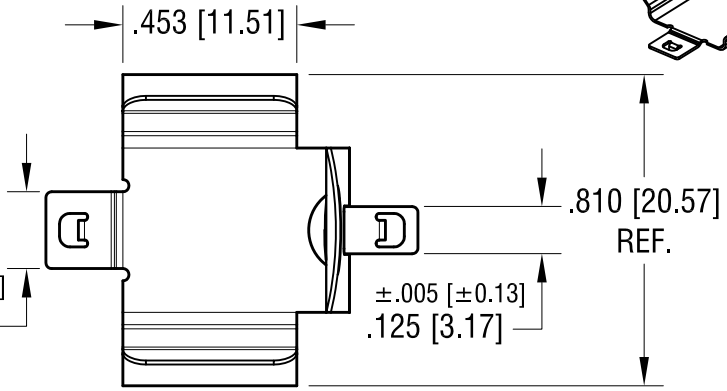
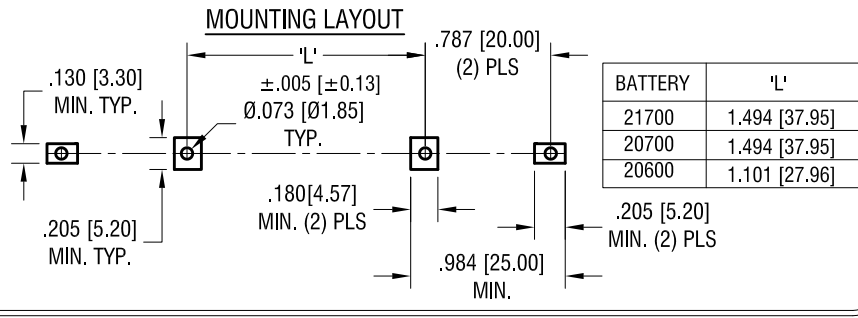
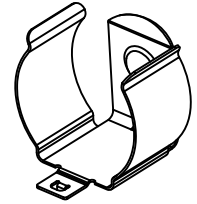

NOTE:
1. HEAT TREAT TO SPRING TEMPER

KEYSTONE ELECTRONICS CORP.

www.keyelco.com • NEW HYDE PARK, NY 11040 • Tel (516) 328-7500

PART NAME
20mm - 21mm SM BATTERY CLIP

MATERIAL
.012 [0.30] TH'K ANNEALED SPRING STEEL

FINISH
TIN NICKEL PLATE

DRN BY NT DATE 10.11.17
APP'D RH SCALE 2X

TOLERANCES INCH [MM]
DECIMAL $\pm .010 [\pm 0.25]$
ANGULAR $\pm 2^\circ$
UNLESS OTHERWISE SPECIFIED

CODE DWG NO. 246

DATE	DESCRIPTION	REV.
6.14.23	(B1) WAS $.609 \pm .015$, (B2) WAS $.060$ CHANGE AS PER ECN 23-100	B
6.14.21	REMOVE HORE HOLE FOR WIRE CHANGE AS PER ECN 21-053	A