

THIS DOCUMENT IS THE PROPERTY OF KEYSTONE ELECTRONICS CORP. AND SHALL NOT BE REPRODUCED, DISTRIBUTED OR USED AS A BASIS FOR MANUFACTURE WITHOUT PRIOR WRITTEN PERMISSION FROM KEYSTONE ELECTRONICS CORP.

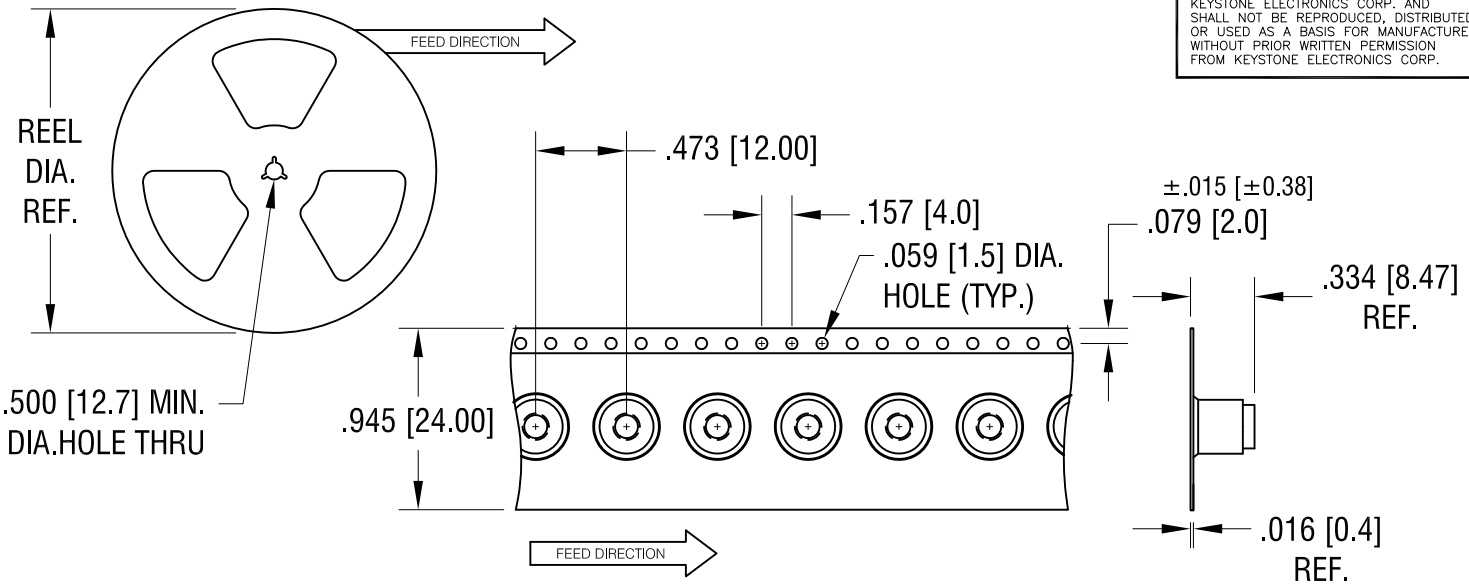

**MOUNTING DETAIL**

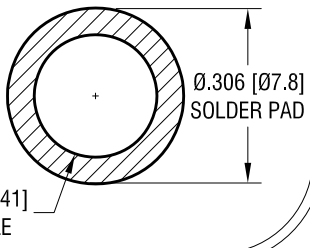

**ACTUAL SIZE**

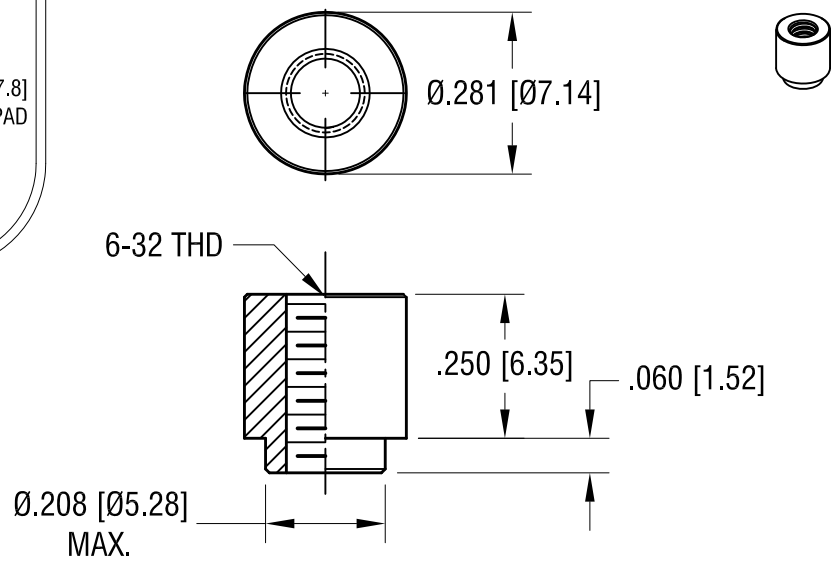

**NOTES:**

- 1. SUPPLIED ON TAPE AND REEL ONLY.  
TAPE AND REEL SPECIFICATIONS:
- 2. TAPE:  
MAT'L - ALL CONDUCTIVE POLYSTYRENE CARRIER  
ANSI/EIA-481 STANDARD
- 3. REEL:  
13" [330.2] DIA. 650 PIECES PER REEL

- 4. REELS TO BE SUPPLIED IN SEALED BAGS WITH VCI PROTECTION.
- 5. KAPTON TAPE ADDED TO TOP SURFACE OF STANDOFF.

<b>KEYSTONE ELECTRONICS CORP.</b>			
www.keyelco.com • NEW HYDE PARK NY 11040 • Tel (516)328-7500			
PART NAME		SM STANDOFF	
MATERIAL		STEEL	
FINISH	MATTE TIN PLATE	DRN BY	NT
		APP'D	RH
		DATE	4.11.16
		SCALE	3X, 1X
TOLERANCES	INCH [MM]	CODE	DWG NO.
DECIMAL	± .005 [± 0.13]	C	<b>4893</b>
ANGULAR	± 1°		
UNLESS OTHERWISE SPECIFIED			

7.29.24	SPECIFIED VCI PACKAGING.	B
8.15.17	CHANGE A PER ECN 17-053	A
DATE	DESCRIPTION	REV.