

THIS DOCUMENT IS THE PROPERTY OF KEYSTONE ELECTRONICS CORP. AND SHALL NOT BE REPRODUCED, DISTRIBUTED OR USED AS A BASIS FOR MANUFACTURE WITHOUT PRIOR WRITTEN PERMISSION FROM KEYSTONE ELECTRONICS CORP.

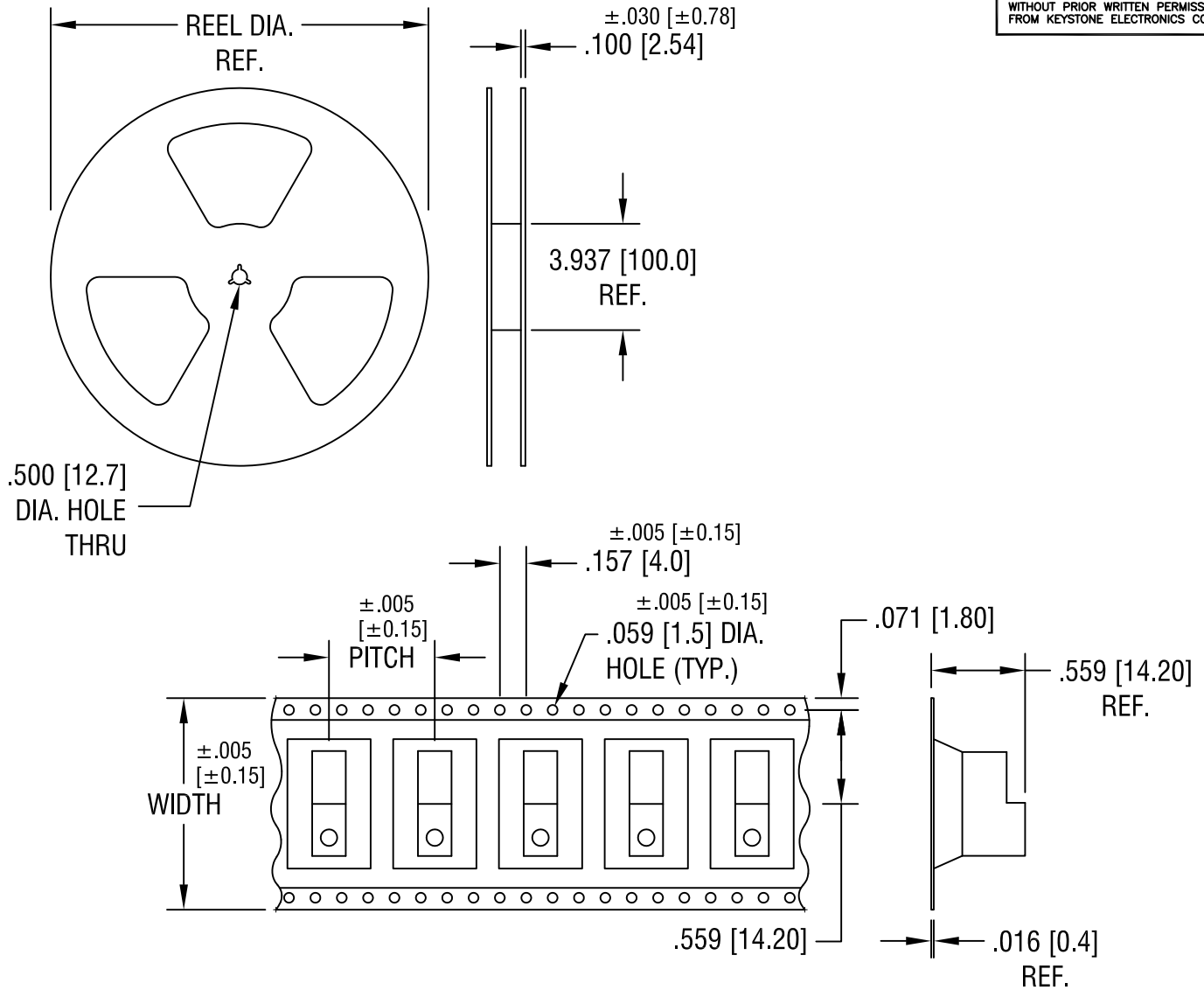

NOTES:

TAPE AND REEL SPECIFICATIONS:

1. TAPE:
 MAT'L - ALL CONDUCTIVE POLYSTYRENE CARRIER
 ANSI/EIA-481 STANDARD
 1.260 [32.0] WIDE; .630 [16.0] PITCH
2. REEL:
 13.0 [330.2] DIA. 250 PIECES OF
 PART NO. 5331 PER REEL.

KEYSTONE ELECTRONICS CORP.			
www.keyelco.com • ASTORIA, N.Y. 11105-2017 • Tel (718) 956-8900			
PART NAME			
SM BATTERY CONTACT, ON TAPE			
MATERIAL			
AS NOTED			
FINISH		DRN BY	DATE
AS NOTED		NT	7.29.09
		APP'D	SCALE
		LN	X
TOLERANCES	INCH [MM]	CODE	DWG NO.
DECIMAL	± .015 [± 0.38]	C/M	5331TR
ANGULAR	± 1°		
UNLESS OTHERWISE SPECIFIED			

DATE	DESCRIPTION	REV.

THIS DOCUMENT IS THE PROPERTY OF KEYSTONE ELECTRONICS CORP. AND SHALL NOT BE REPRODUCED, DISTRIBUTED OR USED AS A BASIS FOR MANUFACTURE WITHOUT PRIOR WRITTEN PERMISSION FROM KEYSTONE ELECTRONICS CORP.

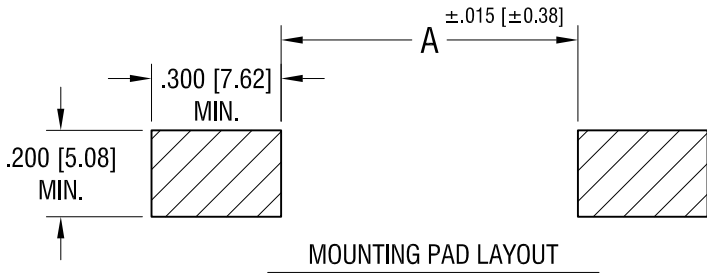

FOR BATTERY SIZE:	'A' DIM.
A	2.170 [55.12]
AA	2.380 [60.45]

ACTUAL SIZE

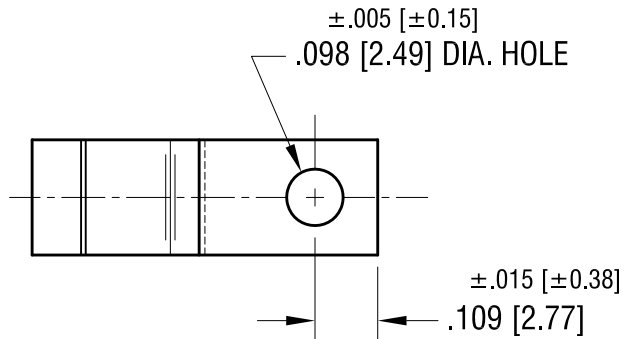
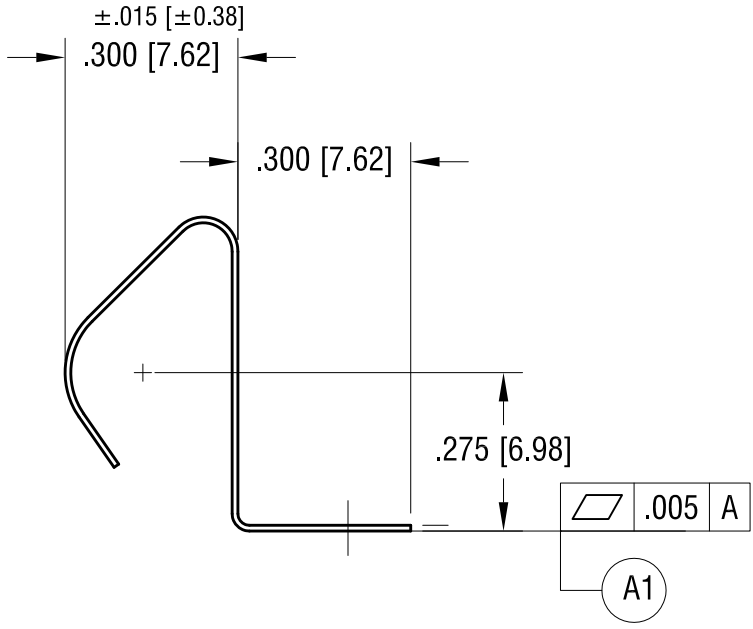
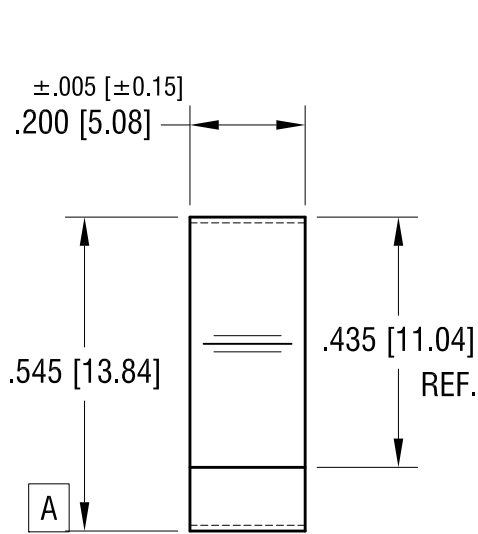
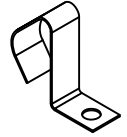

NOTE:

1. HEAT TREAT TO SPRING TEMPER.

ADD FLATNESS (A1)

7.06.20	CHANGE AS PER ECN 20-064	A
DATE	DESCRIPTION	REV.

KEYSTONE ELECTRONICS CORP.			
www.keyelco.com • NEW HYDE PARK, NY 11040 • Tel (516) 328-7500			
PART NAME BATTERY CONTACT, SURFACE MOUNT			
MATERIAL .010 [0.25] TH'K ANNEALED SPRING STEEL			
FINISH MATTE TIN PLATE	DRN BY NT	DATE 7.29.09	
	APP'D RH	SCALE 3X	
TOLERANCES INCH [MM] DECIMAL ±.010 [±0.25] ANGULAR ± 1° UNLESS OTHERWISE SPECIFIED	CODE C	DWG NO. 5331	