

THIS DOCUMENT IS THE PROPERTY OF
KEYSTONE ELECTRONICS CORP. AND
SHALL NOT BE REPRODUCED, DISTRIBUTED
OR USED AS A BASIS FOR MANUFACTURE
WITHOUT PRIOR WRITTEN PERMISSION
FROM KEYSTONE ELECTRONICS CORP.

ACTUAL SUIZE

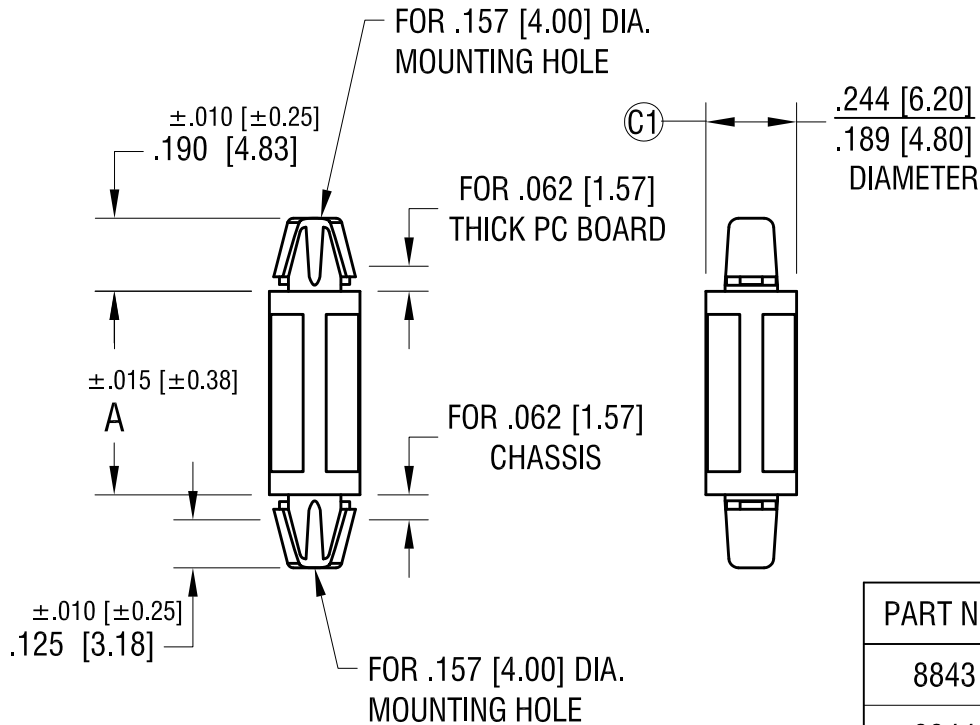

P/N 8847



PART NO.	'A' DIM.
8843	.118 [3.0]
8844	.157 [4.0]
8845	.236 [6.0]
8846	.315 [8.0]
8847	.394 [10.0]
8848	.472 [12.0]
8849	.551 [14.0]
8850	.630 [16.0]
8851	.709 [18.0]

DATE	DESCRIPTION	REV.
8.10.21	ECN 21-079 (C1) WAS .236	C
2.27.07	CHANGE AS PER ECN 07-011	B
12.14.08	ECN 06-088 MAT'L WAS 94V-2	A

KEYSTONE ELECTRONICS CORP.
www.keyelco.com • NEW HYDE PARK, NY 11040 • Tel (516) 328-7500

PART NAME
METRIC PC LOCK-IN SUPPORT

MATERIAL
NYLON UL 94V-0

FINISH NONE	DRN BY BOONE	DATE 3.31.99
	APP'D RH	SCALE 2X

TOLERANCES INCH [MM]	CODE	DWG NO.
DECIMAL ±.005 [±0.13]	M	8843-8851
ANGULAR ± 1° UNLESS OTHERWISE SPECIFIED		