

THIS DOCUMENT IS THE PROPERTY OF
KEYSTONE ELECTRONICS CORP. AND
SHALL NOT BE REPRODUCED, DISTRIBUTED
OR USED AS A BASIS FOR MANUFACTURE
WITHOUT PRIOR WRITTEN PERMISSION
FROM KEYSTONE ELECTRONICS CORP.

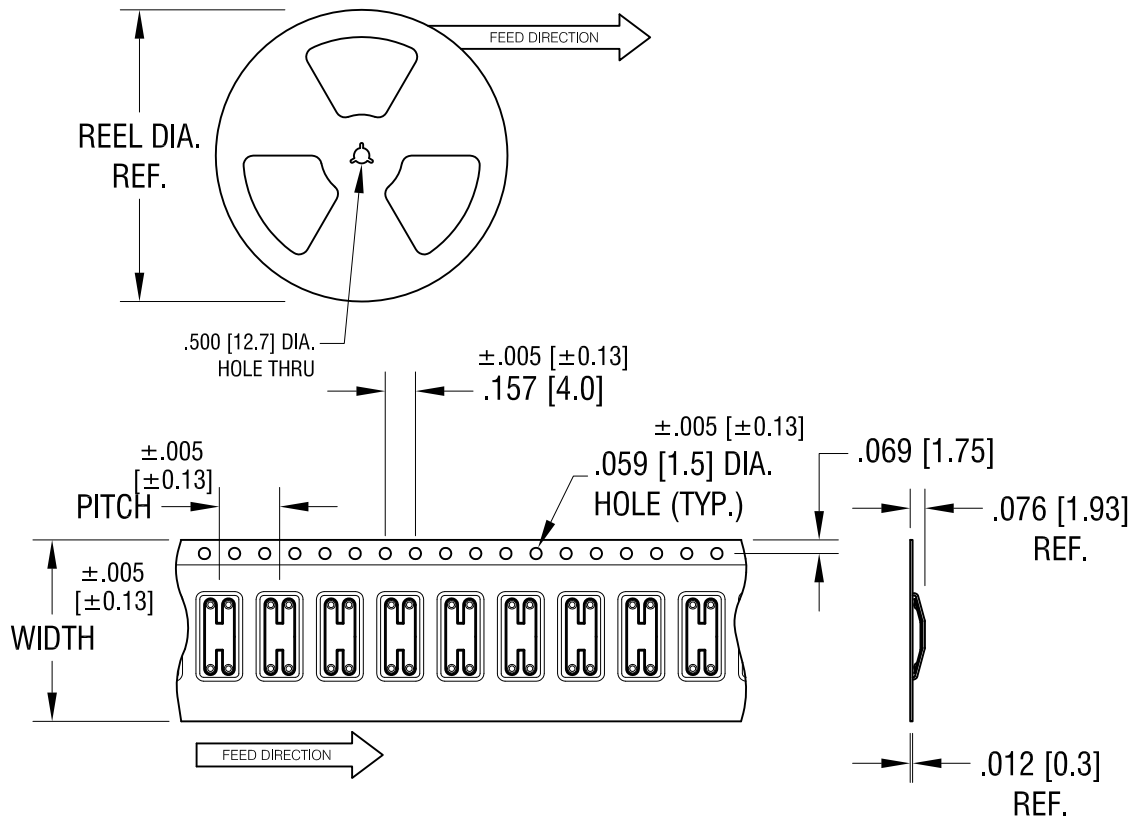

NOTE:

1. TAPE AND REEL SPECIFICATIONS:

TAPE: MAT'L - ALL CONDUCTIVE POLYSTYRENE CARRIER
ANSI/EIA-481 STANDARD, 24 MM WIDE; 8 MM PITCH

REEL: 13.0 [1330] DIA. 5000 PIECES OF P/N 112 REV.D PER REEL.

KEYSTONE ELECTRONICS CORP.			
www.keyelco.com • ASTORIA, N.Y. 11105-2017 • Tel (718) 956-8900			
PART NAME		CONTACT ON TAPE AND REEL	
MATERIAL		AS NOTED	
FINISH		DRN BY	DATE
AS NOTED		HAMILTON	10.07.13
		APP'D	SCALE
		LN	N/A
TOLERANCES		INCH	[MM]
DECIMAL		± .010	[± 0.25]
ANGULAR		± 1°	
UNLESS OTHERWISE SPECIFIED		CODE	DWG NO.
		C	112TR

12.11.14	CHANGE AS PER ECN 14-122	A
DATE	DESCRIPTION	REV.

THIS DOCUMENT IS THE PROPERTY OF KEYSTONE ELECTRONICS CORP. AND SHALL NOT BE REPRODUCED, DISTRIBUTED OR USED AS A BASIS FOR MANUFACTURE WITHOUT PRIOR WRITTEN PERMISSION FROM KEYSTONE ELECTRONICS CORP.

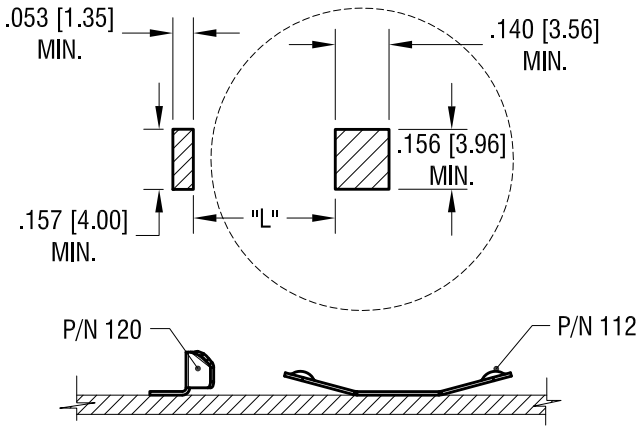

MTG LAY OUT WHEN USE WITH P/N 120

BATTERY DIA.	L
20mm	.336 [8.5]
23mm	.395 [10.0]

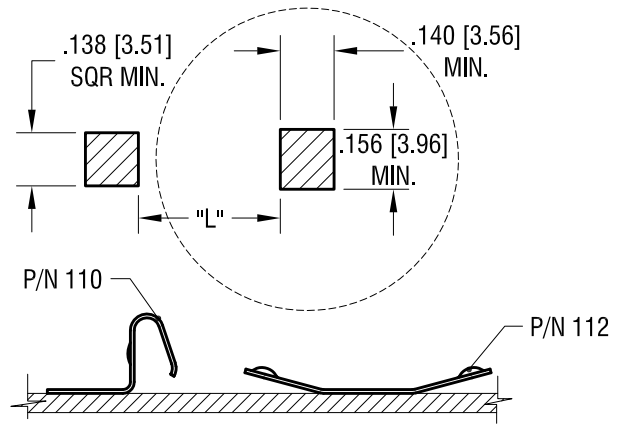

MTG LAY OUT WHEN USE WITH P/N 110

BATTERY DIA.	L
20mm	.370 [9.4]
23mm	.429 [10.9]
24mm	.448 [11.4]
30mm	.567 [14.4]

ACTUAL SIZE

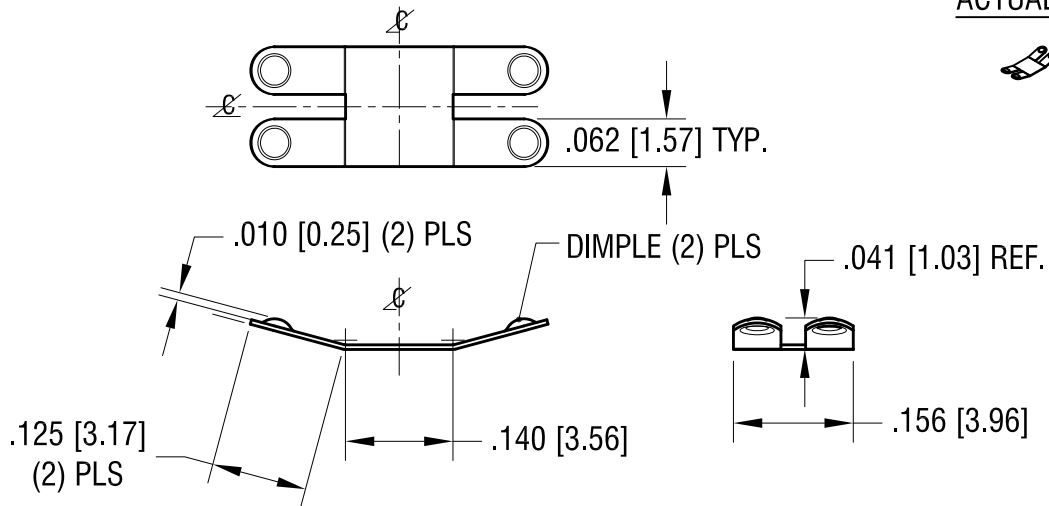

11.13.15	CHANGE AS PER ECN 15-134	F
9.21.15	CHANGE AS PER ECN 15-104	E
12.11.14	CHANGE AS PER ECN 14-121	D
7.24.14	CHANGE AS PER ECN 14-075	C
1.29.14	CHANGE AS PER ECN 14-011	B
12.02.13	CHANGE AS PER ECN 13-104	A
DATE	DESCRIPTION	REV.

KEYSTONE ELECTRONICS CORP.		
www.keyelco.com • ASTORIA, N.Y. 11105-2017 • Tel (718) 956-8900		
PART NAME		
NEGATIVE BATTERY CONTACT		
MATERIAL		
.006 [0.15] TH'K STAINLESS STEEL		
FINISH		DRN BY
GOLD PLATE		NT
		DATE
		10.07.13
		APP'D
		LN
		SCALE
		4X
TOLERANCES	INCH [MM]	CODE
DECIMAL	± .005 [± 0.13]	C
ANGULAR	± 1°	
UNLESS OTHERWISE SPECIFIED		
DWG NO.		112