

THIS DOCUMENT IS THE PROPERTY OF KEYSTONE ELECTRONICS CORP. AND SHALL NOT BE REPRODUCED, DISTRIBUTED OR USED AS A BASIS FOR MANUFACTURE WITHOUT PRIOR WRITTEN PERMISSION FROM KEYSTONE ELECTRONICS CORP.

**MOUNTING LAYOUT**

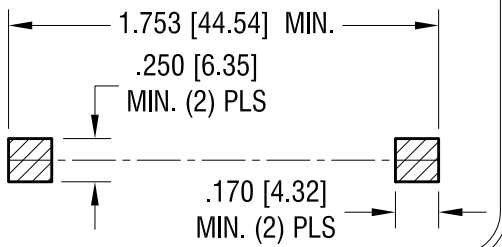

**ACTUAL SIZE**

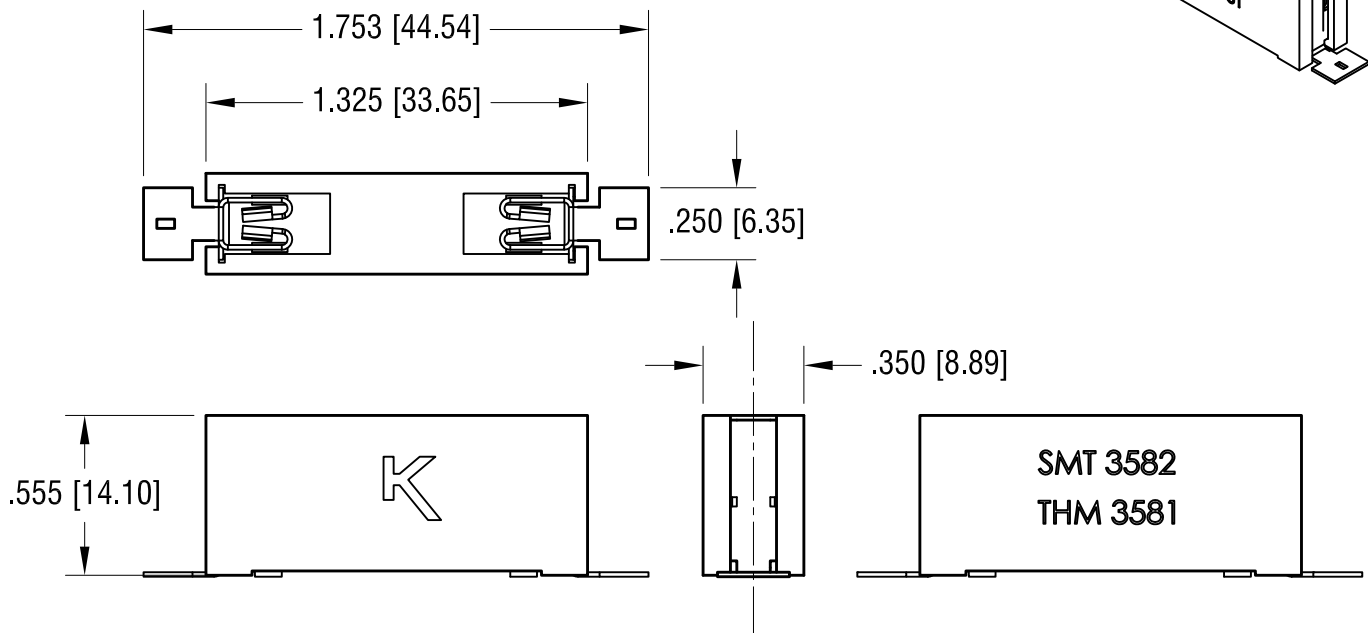
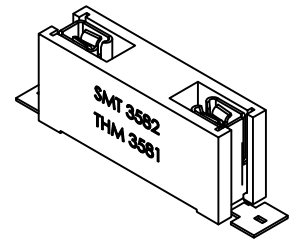

**NOTE:**

1. FUSE CLIP: MAT'L- .016 [0.41] TH'K COPPER  
FINISH- TIN NICKEL PLATE
2. BASE: MAT'L- PA9T (BLACK COLOR)

**KEYSTONE ELECTRONICS CORP.**

www.keyelco.com • NEW HYDE PARK NY 11040 • Tel (516)328-7500

PART NAME				SM MAXI FUSE HOLDER			
MATERIAL				AS NOTED			
FINISH		DRN BY		DATE		SCALE	
AS NOTED		NT		4.01.22		1.5X	
TOLERANCES		INCH		[MM]		CODE	
DECIMAL		± .005		[± 0.13 ]		C	
ANGULAR		± 1°		UNLESS OTHERWISE SPECIFIED		DWG NO.	
						3582	

DATE	DESCRIPTION	REV.